

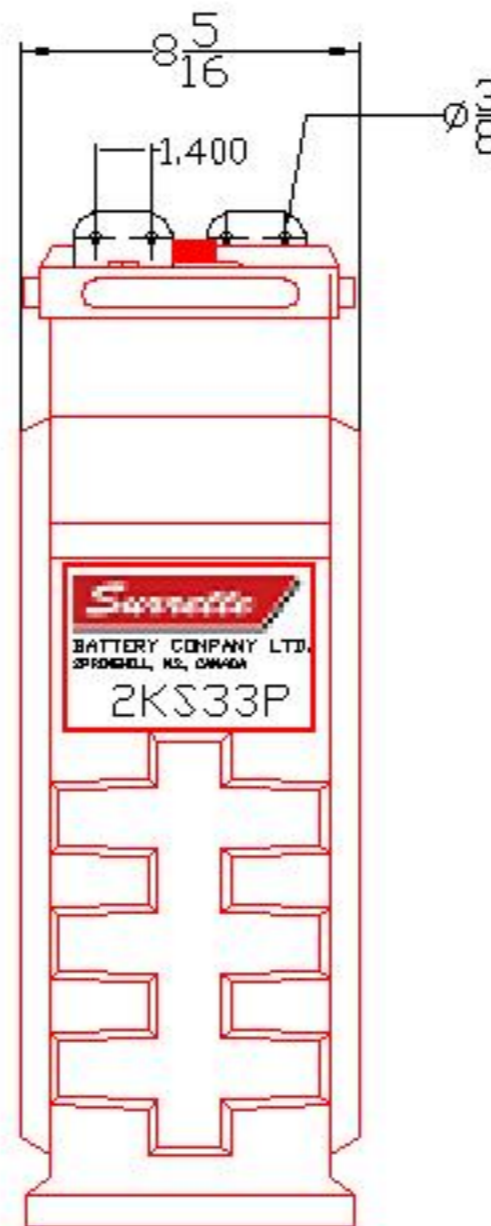

DEEP CYCLE-SOLAR SERIES 5000

BATTERY TYPE	VOLTS	2	2 KS 33PS	
DIMENSIONS				
LENGTH	392 MM	15 7/16	INCHES	
WIDTH	211 MM	8 5/16	INCHES	
HEIGHT	630 MM	24 13/16	INCHES	
WEIGHT DRY	66 KG	145	LBS.	
WEIGHT WET	95 KG	208	LBS.	
CONTAINER CONSTRUCTION				
INNER CONTAINER	POLYPROPYLENE			
INNER COVER	POLYPROPYLENE - HEAT SEALED TO INNER CONTAINER			
OUTER CONTAINER	HIGH DENSITY POLYETHYLENE			
OUTER COVER	HIGH DENSITY POLYETHYLENE SNAP FIT TO OUTER CONTAINER			
HANDLES	MOLDED			
PLATES PER CELL	33			
ELECTROLYTE RESERVE	ABOVE PLATES	95 MM	3.75	INCHES
DESIGN CRITREA	10 YEAR WARRANTY	3300	CYCLES	15 YEAR LIFE
POSITIVE PLATE DIMENSION				
HEIGHT	432 MM	17.0	INCHES	
WIDTH	143 MM	5.625	INCHES	
THICKNESS	6.99 MM	0.275	INCHES	
NEGATIVE PLATE DIMENSION				
HEIGHT	432 MM	17.0	INCHES	
WIDTH	143 MM	5.625	INCHES	
THICKNESS	4.57 MM	0.180	INCHES	
SEPARATOR	SEPARATOR THICKNESS	0.105 INCH		
INSULATION	POSITIVE PLATE DOUBLE WRAPPED WITH SLYVER 0.020 HEAVY GLASS MAT AND ENVELOPED WITH HEAVY DUTY SEPARATOR			
TERMINALS	FLAG WITH STAINLESS STEEL NUTS AND BOLTS			
COLD CRANK	CCA	0°F / -17.8°C	4952	RESERVE
	MCA	32°F / 0°C	6190	MINUTES AT 25A
				4915
CAPACITY	20 HR RATE	1766		
		CAP / AH	CURRENT / AMPS	
CAPACITY AT THE 100 HOUR RATE	1.265 SP. GR.	2490	24.90	
CAPACITY AT THE 72 HOUR RATE	1.265 SP. GR.	2349	32.62	
CAPACITY AT THE 50 HOUR RATE	1.265 SP. GR.	2172	43.44	
CAPACITY AT THE 24 HOUR RATE	1.265 SP. GR.	1837	76.5	
CAPACITY AT THE 20 HOUR RATE	1.265 SP. GR.	1766	88.3	
CAPACITY AT THE 15 HOUR RATE	1.265 SP. GR.	1642	109.5	
CAPACITY AT THE 12 HOUR RATE	1.265 SP. GR.	1536	128.0	
CAPACITY AT THE 10 HOUR RATE	1.265 SP. GR.	1466	146.6	
CAPACITY AT THE 8 HOUR RATE	1.265 SP. GR.	1377	172.2	
CAPACITY AT THE 6 HOUR RATE	1.265 SP. GR.	1254	209.0	
CAPACITY AT THE 5 HOUR RATE	1.265 SP. GR.	1183	237	
CAPACITY AT THE 4 HOUR RATE	1.265 SP. GR.	1095	274	
CAPACITY AT THE 3 HOUR RATE	1.265 SP. GR.	989	330	
CAPACITY AT THE 2 HOUR RATE	1.265 SP. GR.	848	424	
CAPACITY AT THE 1 HOUR RATE	1.265 SP. GR.	600	600	

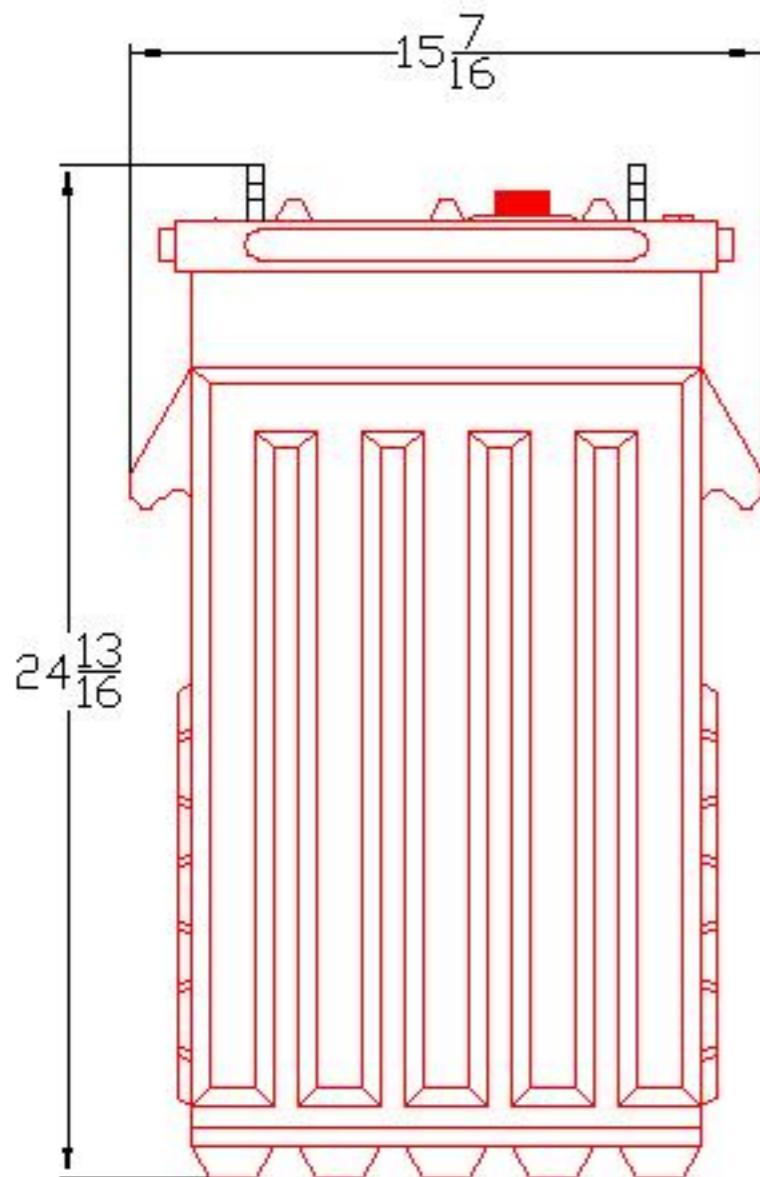
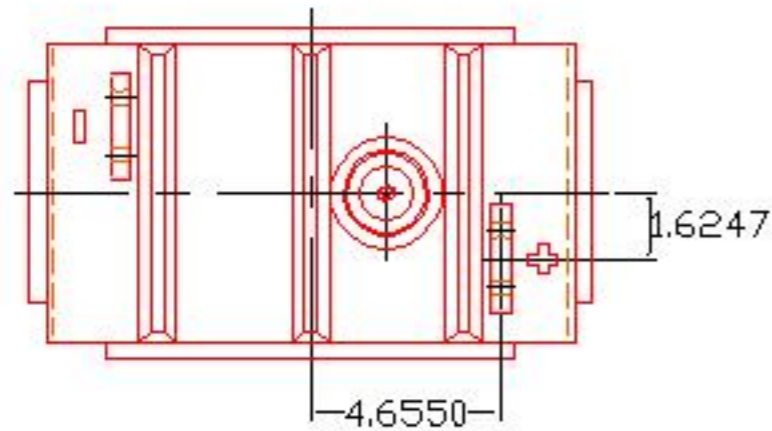

PART NUMBER: 2-KS-33P

WEIGHT WET: 208 LB/ 94 KG

WEIGHT DRY: 145 LB/ 66 KG

CAPACITY
 1,448 AH 8 HR
 1,766 AH 20 HR
 2,491 AH 100 HR

OVERALL DIMS: 15 7/16 X 8 5/16 X 24 13/16



MAX HT WITH OPTIONAL 25 1/2" HYDROCAPS



BATTERY COMPANY LTD.
 SPRINGHILL, NOVA SCOTIA, CANADA

TITLE: 2 KS 33P

DESCRIPTION:
 2V / 1 CELL 33 PLATE 500/5000 SERIES

CONTACT INFO:
 WEB: WWW.SURRETTE.COM
 E-MAIL: SALES@SURRETTE.COM
 PHONE: 1-800-681-9914

SCALE: 1" = 6" JPEG:
 8.5" X 11" NOT TO SCALE

DATE: 20-APR-04 REVISION REV 1

DRAWING NO: DWG 066, BD2KS33P